

Cylinder hydrauliczny dwustronnego działania

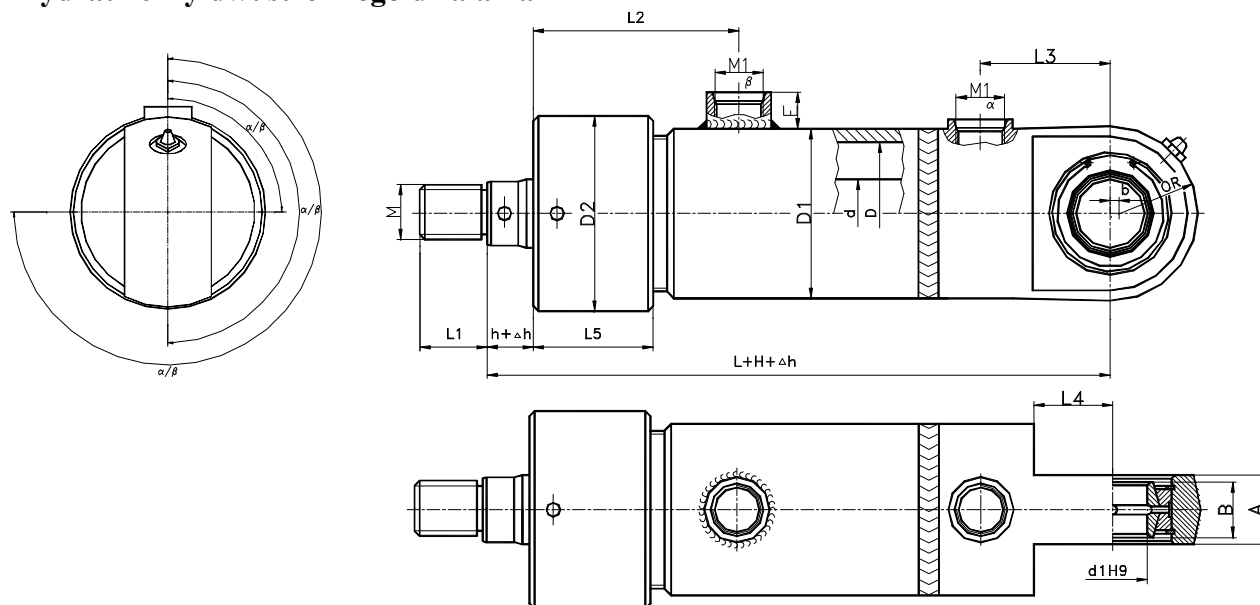

SHB2(A)xDxDxH/Δhxcαβ

WARUNKI TECHNICZNE

- ciśnienie nominalne - 16 MPa
- ciśnienie maksymalne - 20 MPa

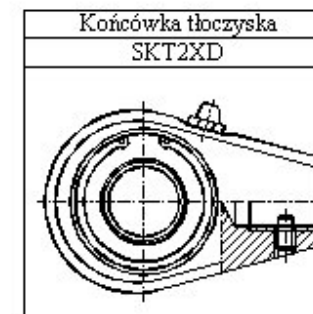

Uwaga: Gniazda gwintowe M1 wg PN-64M-73101. Możliwość wykonania wg PN-ISO 6149-1:1995 lub DIN 3852.

D	d	d1 H9	M	M1	L	L1	L2	L3	L4	L5	h	D1	D2	E	A	B	b	OR	Długość tłumienia	Oznaczenie	Masa [kg]
40	20	20	M16x1,5	M12x1,5	191	18	60	38	22	35	29	50	57	15	20 ₋₁	16	2,5	25,5	-	SHB2Ax40MxH/Δhxcαβ	2,1+0,006H
50	25	30	M20x1,5	M16x1,5	220	22	72	48	29	35	32	65 ₋₃	71	15	30 ₋₁	22	3,5	31,5	-	SHB2Ax50MxH/Δhxcαβ	3,8+0,011H
65	32	40	M24x1,5	M20x1,5	255	30	78	62	38	40	25	80 ₋₅	88	17	40 ₋₁	28	4	40	-	SHB2Ax65MxH/Δhxcαβ	7,9+0,017H
80	40	50	M30x1,5	M20x1,5	295	35	89	79	53	45	34	95 ₋₃	104	17	50 ₋₁	40	6	55	30	SHB2(A)x80MxH/Δhxcαβ	12,6+0,022H
	50	50	M30x1,5	M20x1,5	295	35	89	79	53	45	34	95 ₋₃	104	17	50 ₋₁	40	6	55	30	SHB2(A)x80Mx50xH/Δhxcαβ	13,1+0,028H
100	50	60	M39x2	M27x2	339	40	97	92	65	45	35	120 ₋₅	133	19	60 _{-1,5}	50	9	65	34	SHB2(A)x100MxH/Δhxcαβ	24,7+0,040H
	60	60	M39x2	M27x2	339	40	97	92	65	45	35	120 ₋₅	133	19	60 _{-1,5}	50	9	65	34	SHB2(A)x100Mx60xH/Δhxcαβ	25,8+0,047H
110	60	60	M45x2	M27x2	355	40	104	92	65	50	40	130 ₋₅	141	19	60 _{-1,5}	50	9	70	36	SHB2(A)x110MxH/Δhxcαβ	30,7+0,050H
	70	60	M45x2	M27x2	355	40	104	92	65	50	40	130 ₋₅	141	19	60 _{-1,5}	50	9	70	36	SHB2(A)x110Mx70xH/Δhxcαβ	32,1+0,058H
125	70	70	M48x2	M27x2	387	45	120	100	70	50	33	150 ₋₅	158	19	70 _{-1,5}	60	12	80	40	SHB2(A)x125MxH/Δhxcαβ	43,5+0,059H
	80	70	M48x2	M27x2	387	45	120	100	70	50	33	150 ₋₅	158	19	70 _{-1,5}	60	12	80	40	SHB2(A)x125Mx80xH/Δhxcαβ	45,3+0,068H
140	70	80	M48x2	M27x2	416	55	124	120	80	55	38	165	175	19	70 _{-1,5}	65	10,5	87,5	45	SHB2(A)x140MxH/Δhxcαβ	58,0+0,074H
	80	80	M48x2	M27x2	416	55	124	120	80	55	38	165	175	19	70 _{-1,5}	65	10,5	87,5	45	SHB2(A)x140Mx80xH/Δhxcαβ	59,8+0,083H
160	80	80	M52x2	M33x2	460	65	122	120	80	65	50	185	206	25	70 _{-1,5}	65	9,5	92,5	50	SHB2(A)x160MxH/Δhxcαβ	78,4+0,092H
	90	80	M52x2	M33x2	460	65	122	120	80	65	50	185	206	25	70 _{-1,5}	65	9,5	92,5	50	SHB2(A)x160Mx90xH/Δhxcαβ	80,6+0,103H